



DIONICS, INC.

65 Rushmore Street
Westbury, NY 11590

Phone: (516) 997-7474

Fax: (516) 997-7479

Website: www.dionics-usa.com

DIH-144-SM Power MOSFET Dual N/O SPST Photovoltaic DC Relay

Features:

- Package Contains Two N/O DC Relays
- Fast Switching Speeds
- Optically Isolated to 400V DC.
- Immune to False Triggering
- Hermetic Gull-Wing Surface Mount Package
- Y-Level MIL-Screening Available (**DIH-144-SMY**)
- Designed to Meet MIL-R28750 and 28V DC System Surge and Spike Requirement of MIL STD-704.
- Operation Temp. -40°C to 85°C @ 200mA Load (*Above 85°C Derate Load $5\text{mA}/^{\circ}\text{C}$*)

Applications:

- Replacement of Mechanical Relays
- Motor Control & Power Control
- Aircraft Flight Control Systems
- A.T.E (Automatic Test Equipment)
- Load Control From Processor I/O Ports
- Power Supply Circuits
- Medical Electronics
- Tactical Aircraft

Description:

The DIH-144-SM is a State-of-the-Art Photovoltaic Solid State Relay designed for 28V DC Aircraft power applications where speed, current overload protection and immunity to transient voltages are critical.

The DIH-144-SM contains current limiting networks and thermally sensitive integrated circuits that disable the output, if the output MOSFETs approaches an unsafe operating temperature. Because the thermally sensitive integrated circuits have built-in hysteresis, the output MOSFETs are automatically restarted when a safe temperature is reached. This auto restart feature eliminates the need for system restart signals. If the overload condition continues to exist, the cycle is repeated; if the overload condition is removed, the relay returns to normal operation.

The gull-wing surface mount package contains two independent N/O relays, with separate LED inputs and optically isolated power MOSFET outputs. Each relay, A or B, is capable of carrying 350mA DC continuous current and 500mA DC peak current. Each LED optically couples to a Photovoltaic (PV) IC chip which responds by generating a voltage. This voltage is internally connected to the Gate and Source terminals of the output MOSFETs, thus controlling their current. The DIH-144-SM is also available screened to military specifications, as required.

Package Layout:

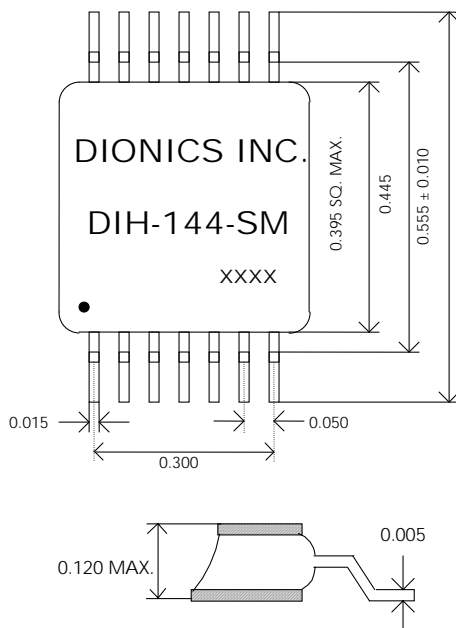

DIH-144-SM Equivalent Circuit:

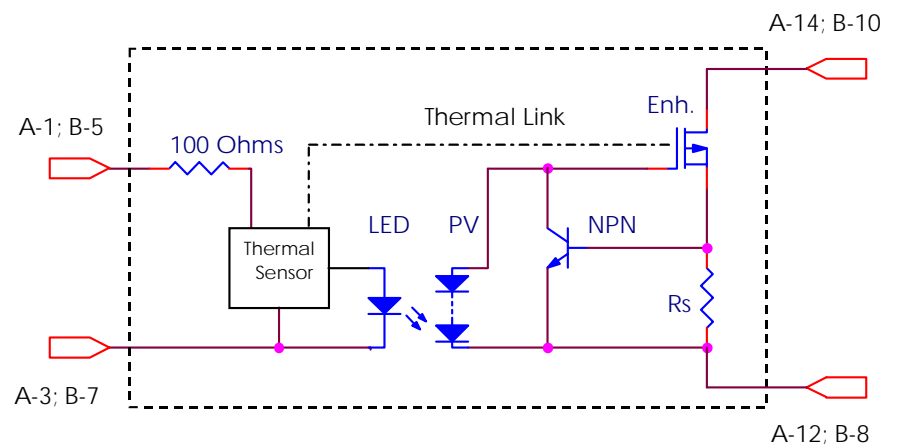

DIH-144-SM: Power MOSFET Dual SPST Photovoltaic DC Relay
Electrical Characteristics: (Per Relay @ 25⁰C unless otherwise specified)

- ❖ Relay A: Normally Open (N/O)
- ❖ Relay B: Normally Open (N/O)

❖ Input Characteristics					
Symbol	Parameter	Min.	Typ.	Max.	Unit
I_{in}	Input Current	5.0	15.0	24.0	mA
V_{in}	Input Voltage Drop	1.3	—	1.5	V
$V_{rev.}$	Reverse Voltage	—	—	10.0	V
V_{on}	On State Voltage	3.5	—	—	V
V_{off}	Off State Voltage	—	—	1.5	V

❖ Pin Designations				
Relay	Pin Number	Inputs	Pin Number	Outputs
Relay A	1	A +	14	Drain A +
	3	A -	12	Source A -
Relay B	5	B +	10	Drain B +
	7	B -	8	Source B -
	2,4,6	NC	9,11,13	NC

❖ Output Characteristics					
Symbol	Parameter	Typ.	Max.	Unit	Conditions
I_{load}	Load Current	—	350 / 500	mA	Continuous / Peak
R_{on}	On Resistance @ $T_a = 85^0C$	—	2	Ω	$I_{in}=18 (mA); I_{load} = 100 (mA)$
		—	3	Ω	$I_{in}=18 (mA); I_{load} = 100 (mA)$
I_{leak}	Leakage Current	—	10	μA	$V_{op}=90 (V)$
R_{iso}	Input/Output Resistance	10^8	—	Ω	$V_{In-Out} = 300 (V)$
V_{op}	Operating Voltage	28	60	VDC	Limited by Power Dissipation
BV	Breakdown Voltage	—	95	VDC	At 100 (μA)
T_{on}	Turn-On Time	150	300	μs	$V_{in} = 4.5(V); P.W^* = 100(ms); V_{op} = 30(V)$
T_{off}	Turn-Off Time	20	40	μs	$V_{in} = 4.5(V); P.W^* = 100(ms); V_{op} = 30(V)$
V_{iso}	Input-Output Isolation	—	400	V	DC
P	Maximum Power Dissipation	—	400	mW	In Free Air
High Temp. & Current	Simulate over temp. and over current test	Pre-heat the relay to 140 ⁰ C; $I_{in} = 15mA; I_{Load} = 500mA$; Relay is on-off for 10 sec; Remove 500mA load; Make sure relay returns to normal operation			

❖ Optional Test and Packaging			
Option 1	Burn-In	Duration = 72 Hrs at 90 ⁰ C	$I_{in} = 20(mA); I_{Load} = 100(mA)$ at 28(V)
Option 2	Lead Tinning: 63% Tin; 37% Silver.		
Option 3	Tape and Reel Packaging (Please contact us for detail information)		

PW: Pulse Width.*

❖ Timing Diagram

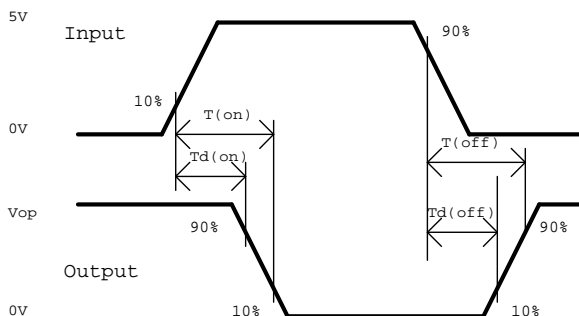

❖ Environmental Ratings:

- Storage Temperature: -55⁰C to +125⁰C
- Constant Acceleration: 5000G
- Hermeticity:
 - ✓ Gross 1×10^{-5} atm cc/sec
 - ✓ Fine 5×10^{-8} atm cc/sec **

** When screened to MIL-Specs.