



DIONICS, INC.

65 Rushmore Street
Westbury, NY 11590

Phone: (516) 997-7474

Fax: (516) 997-7479

Website: www.dionics-usa.com

LEVEL-SHIFTED VACUUM FLUORESCENT DISPLAY DRIVERS

DI-512BR* DI-513BR DI-514BR

(* Also directly applicable as gas discharge display digit driver. Pin for pin replacement for SPRAGUE UDN6184A)

General Description:

The DIONICS DI-512BR, DI-513BR and DI-514BR circuits are designed for interfacing between MOS or TTL logic circuitry and vacuum fluorescent display panels. Each section of these devices consists of a switched constant current level shifter (capable of 50 Volt, 80 Volt or 110 Volt operation) and a PNP-NPN driver transistor pair. The constant current operation of the level shifter stage results in low power dissipation. Input circuitry is suitable for open drain PMOS, CMOS, open-collector or standard TTL.

Features:

- ✓ 50V, 80V and 110V Level Shift Capability
- ✓ MOS and TTL Compatibility
- ✓ Segment and Digit Drivers
- ✓ Low Power Dissipation
- ✓ Reliable Silicon Dielectrically IC Process
- ✓ Pin for Pin replacement for SPRAGUE UDN6118A, UDN6128A

Package Layout:

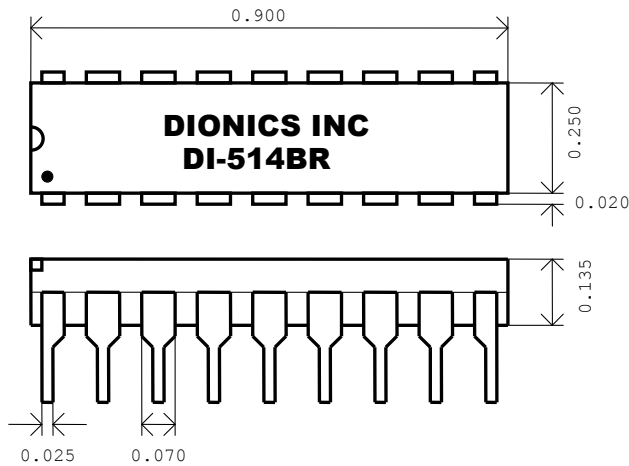

DI-512BR DI-513BR DI-514BR

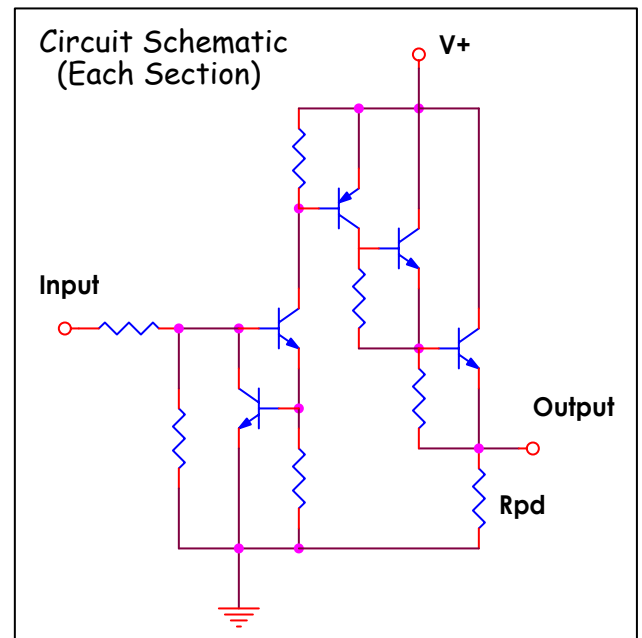
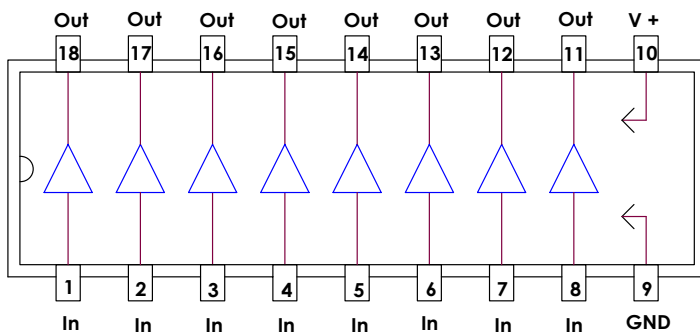

Absolute Maximum Ratings ($T_A = 25\text{ }^\circ\text{C}$)

Characteristic	Symbol	Note	Limit			Unit
			DI-514BR	DI-513BR	DI-512BR	
Supply Voltage	V_{CC}	Measured with respect to GND terminal	50	80	110	V
Input Voltage	V_I	Measured with respect to GND terminal	30	30	30	V
Output Voltage	V_O	Measured with respect to V+ terminal	50	80	110	V
Output Current	I_O		30	30	30	mA
Power Dissipation	P_D	Derate at $8\text{mW}/^\circ\text{C}$, above $25\text{ }^\circ\text{C}$ ambient	800	800	800	mW
Storage Temperature	T_S		$-55\text{ }^\circ\text{C}$	T_o	$+125\text{ }^\circ\text{C}$	$^\circ\text{C}$
Operating Temperature	T_O		$0\text{ }^\circ\text{C}$	T_o	$+70\text{ }^\circ\text{C}$	$^\circ\text{C}$

Electrical Characteristics ($T_A = 25\text{ }^\circ\text{C}$)

Parameter	Symbol	Note	Condition	Typ.	Max.	Unit
Output Saturation Voltage	$V_{OS(ON)}$	Measured with respect to V+ terminal	$I_O = 20\text{mA}$; $V_I = 2.4\text{V}$; $V_{CC} = 40\text{V}$	3	5	V
Supply Leakage ❖ DI-514BR ❖ DI-513BR ❖ DI-512BR	$I_{CC(OFF)}$	Derate at $8\text{mW}/^\circ\text{C}$; above $25\text{ }^\circ\text{C}$ ambient	$V_I = 0.4\text{V}$; $V_{CC} = 50\text{V}$	10	15	μA
			$V_I = 0.4\text{V}$; $V_{CC} = 80\text{V}$	10	15	μA
			$V_I = 0.4\text{V}$; $V_{CC} = 110\text{V}$	10	15	μA
Input Current	$I_{O(ON)}$		$V_I = 2.4\text{V}$	300	400	μA
Supply Current	I_{CC}	One Input at 2.4V , Other at 0.4V	$I_O = 0\text{mA}$; $V_I = 0.4\text{V}$; $V_{CC} = 50\text{V}$	0.5	1.0	mA
				Min.	Max.	Unit
Pull down Current	I_{PD}		$I_O = 0\text{mA}$; $V_I = 0.4\text{V}$; $V_O = 40\text{V}$	200	500	μA
Pull down Resistors	R_{PD}			80	200	$\text{k}\Omega$

Typical Application:

